

## “Wedge” and Latch Support options

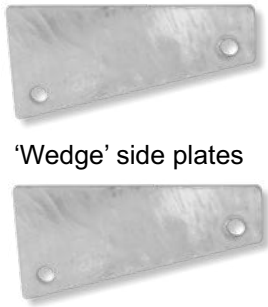

'Wedge' side plates



The 'Latch Support'  
(use if the Latch has no support  
at the front)



The 'Wedge'  
(if you have both a support & angle  
problem)

### ► Why the 'Wedge' is used ?

Good performance with the L & R Boat Latch is achieved by having the correct angle where the Latch meets the Snare. Roughly measure this angle. The “Wedge” allows you to change the angle by 14 degrees up or down. The alternative is to use another Winch Plate or Winch Post. To help you work out the angle there is a printed paper guide on the web at [www.boatlatch.com](http://www.boatlatch.com) at the back of the “Before you Install” brochure.

You can create a vertical by tying a nut to a bit of string and hanging it on the boat and the trailer.

### The right Angle of the Latch to the Snare

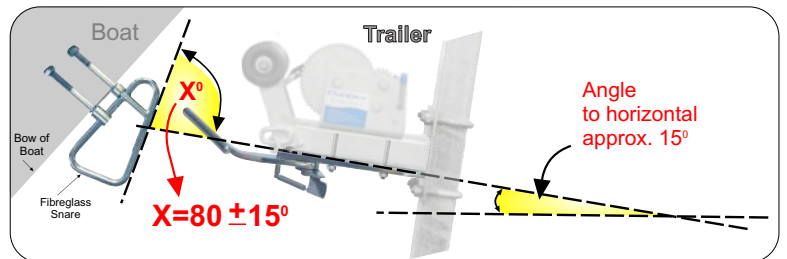

Note:- There is an angle guide on the website at the end of the Install document



► Tilt 14 degrees UP



► Tilt 14 degrees DOWN

### ► Why is the Latch Support & Wedge Plates only made of galvanised mild steel ?

Cost - Marine grade stainless steel is extremely expensive. Normally the Latch is bolted to the trailer winch support which is usually galvanised mild steel anyway. It is preferable if the Latch and the trailer and/or Latch support are isolated with a coating. Corrosion can occur between dissimilar metals. Compounds such as Duralac are suitable - this is available through a number of marine component dealers.



### ► Why are the bolts not supplied ?

Because there are several bolt possibilities. We want to keep the cost down and if we supply both alternatives, the other option that is not used will be thrown away. One alternative is to use two long bolts that joint the pair of holes on the 'wedge' side plates. However if, in your configuration the winch bolts come down in a position through the 'Wedge' and hit either of this pair of long bolts you will need to use some short bolts on either side instead (see photo). There are numerous variations of winches and their bolt hole layouts.

### ► Note on Winch Bolts used

You may have to use longer winch bolts, depending on your set up. Many winches require high tensile bolts and they are not always fitted. Also some winch manufacturers specify the use of three bolts, two at the front and one at the rear, but so often only two are fitted. For large boats two are recommended at the front. If you get longer bolts, best option is to get corrosion resistant high tensile bolts.

### ► Bolt Sizes

The sizes we have allowed for are 10 mm diameter metric bolts. You can also fit 3/8 inch bolts. You should use spring washers and/or nylon locking nuts to stop the nuts from vibrating off.

### ► Examples where you would use the “Wedge”



Here are two examples where the 'Wedge' would sort out the angle problem.

The ski boats Latch to Snare angle is about 58 to 62° which is too low, and the 'Wedge' will bring them nicely into the right operating range.

## "Latch Support" option



The 'Latch Support'

### In What Situations Would You Need a Latch Support ?

Where the front of the latch is sitting out 'in space' with no backing support and no surface to mount the front latch bolt.

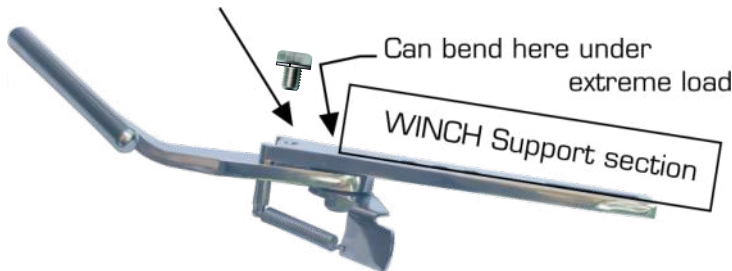

In these circumstances the front of the latch can bend in extreme situations and ruin its functionality.

Note - this front bolt needs to be installed otherwise you will void the warranty.

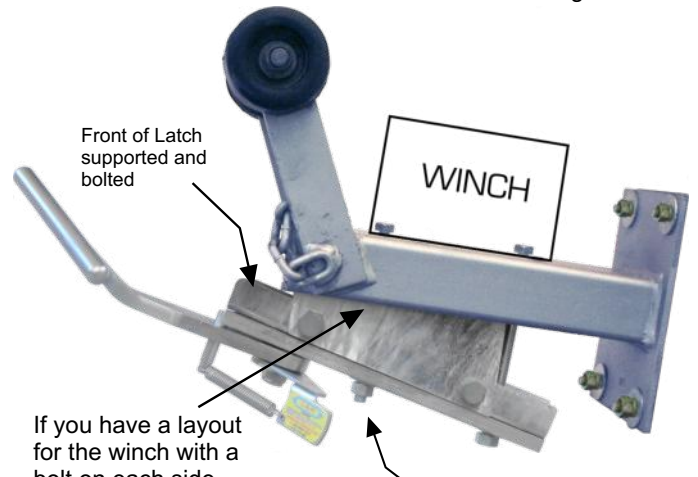
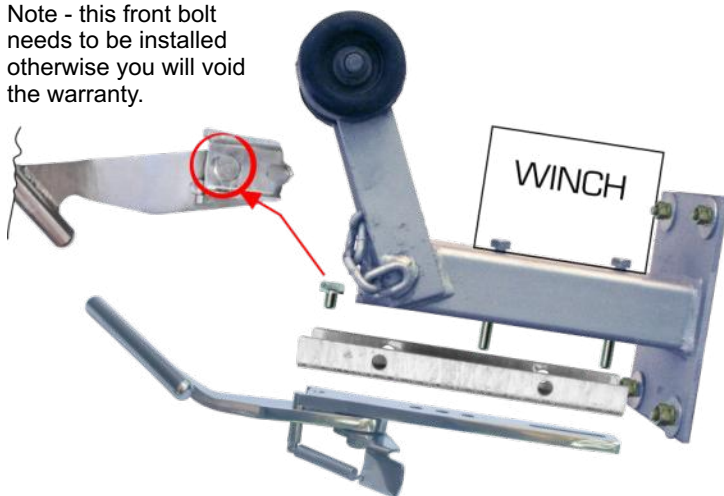

If you have a layout for the winch with a bolt on each side, you may need (for some winch brands) to remove a bit of the side plate to cope with the bolt head.

Watch that bolt thread does not get in the way of the 'path' of the 'Selector Lever' - cut off surplus or reverse bolt so the head is here and not the nut.

### Installing Bolts

The front bolt is vital to brace up the strength should you wind up accidentally hitting the wharf, or some other issues where extreme forces are involved.



Note - this front bolt needs to be installed otherwise you will void the warranty.

Can use one long bolt in place of two short ones, if the winch bolts do not get in the way. Note- bolts should be galvanised and have spring washers.

### Latch Support projecting beyond the winch plate

